



Convention Dates  
(Norway)

Dec. 21, 1935:  
Feb. 24, 1936:

Corresponding Applications  
in United Kingdom

No. 34815/36. }  
No. 34816/36. } dated Dec. 18, 1936.

(One Complete Specification Left under Section 91 (2) of the Patents and Designs Acts, 1907 to 1932.)

Specification Accepted: Oct. 29, 1937.

### COMPLETE SPECIFICATION

#### Portable Cooking-stoves

I, FRITHJOF LEHRE, of Norwegian Nationality, of Övre Slottsgate 15 b, Oslo, Norway, do hereby declare the nature of this invention and in what manner the same is to be performed, to be particularly described and ascertained in and by the following statement:—

5 The present invention relates to a cooking apparatus, particularly adapted for sport purposes, and the object of the invention is to provide a cooking apparatus of this kind, which is simple to use, occupies a small space and is well protected during transport.

10 The cooking apparatus comprises a container for liquid fuel and a burner attached to the same, and the main feature of the invention consists therein that the burner is enclosed in a jacket consisting of two flaps pivotally connected with each other and with the burner frame in such a manner that they are adapted, when opened, to form a support for the cooking utensil, whereas in a closed position the flaps form a complete enclosure for the burner.

15 In accordance with a further feature of the invention the part of the frame to which the two jacket flaps are pivotally connected, is slidably connected with the fuel container and the burner, so that the two flaps during the use of the apparatus may be pulled some distance away from the fuel container and the burner.

20 On the accompanying drawing figures 1 and 2 illustrate an embodiment of the invention, figure 1 being a sectional side view and figure 2 a plan.

1 is the fuel container, which is preferably formed as a cylinder, and is provided in the usual manner with a filling opening 2 and a pressure pump 3 for putting the liquid fuel under pressure.

45 A burner 5 is secured to an arm or plate extending from one end of the fuel container 1, the burner being preferably of the kind adapted to utilize vaporized liquid fuel, although it may also be an ordinary wick burner, the burner being

connected with the fuel container 1 by means of a pipe.

On the free end of arm 12, 13 the two flaps 8, 9 are pivotted, said flaps being preferably made in a semicylindrical form and being adapted to be pivotted in opposite directions in a plane perpendicular on the axis of the burner.

Of the two parts 12, 13, forming the support for the burner, the part 12 carrying the trunnion 10 for flaps 8 and 9, is slidably connected with the stationary part 13 fixed upon the fuel container 1, and carrying the burner 5, the said support and burner being enclosed between the flaps 8 and 9 when these are in their closed position.

On the drawing the slide is shown pulled out to a certain extent for the use of the apparatus, by cooking, whereas on figure 2 the form of the apparatus with closed flaps 8, 9 and the slide in its innermost position is indicated with dotted lines.

In the open position as indicated on figure 2 the flaps 8, 9 of the jacket form the support for cooking utensils, in some cases in connection with a bracket or knob 11 on the fuel container.

When the jacket flaps are closed and the slide is in its innermost position the jacket flaps fit about the free ends of the fuel container 1 forming a cylindric or substantially cylindric elongation of the fuel container, whilst completely enclosing the burner.

The parts 8, 9 and in some cases also the part of the fuel container 1 adjacent the burner may be covered with asbestos or the like.

Further, as indicated on the drawing, a protecting disk 14 may be located between the fuel container and the burner.

In the embodiment illustrated on the drawing, in accordance with which the flaps 8, 9 are pivotted on a trunnion secured to the free end of slide 12, some advantages are obtained when using the apparatus in free air, as the flaps 8, 9

may then be placed in such a position as to act as a wind screen for the burner.

Having now particularly described and ascertained the nature of my said invention, and in what manner the same is to be performed, I declare that what I claim is:—

1. Cooking apparatus, particularly for sport purposes, comprising a fuel container and a burner rigidly attached to the same, characterized in this that the burner is enclosed in a jacket consisting of two flaps pivotally connected with a member associated with the fuel container and the burner in such a manner that the flaps are adapted in open position to form a support for cooking utensils and the like and to completely enclose the burner when they are in a closed position.

2. Cooking apparatus as claimed in claim 1, characterized therein that the pivotted jacket flaps when in closed position fit about the fuel container in such a manner that the part of the fuel container adjacent the burner forms one wall in the closed chamber about the burner when the flaps are closed.

3. Cooking apparatus as claimed in

claim 1, with a fuel container in the form of a cylinder, characterized in this that the burner is mounted on an arm or plate extending from one end of the fuel container, the jacket comprising two substantially semi-cylindrical members pivotted to the free end of the arm or plate carrying the burner, said flaps forming in a closed position a substantially cylindrical extension of the fuel container.

4. Cooking apparatus as claimed in claims 1 and 3, characterized in this that the member to which the two jacket flaps are pivotted, is slidably connected with the fuel container and burner in such a manner that the jacket flaps may be removed some distance from the fuel container and the burner during the use of the apparatus.

5. Cooking apparatus as claimed in claim 1, characterized in this that a protecting disk (14) is located between the fuel container and the burner in order to protect the container against radiated heat.

Dated the 18th day of December, 1936.  
MARKS & CLERK.

Fig. 1.

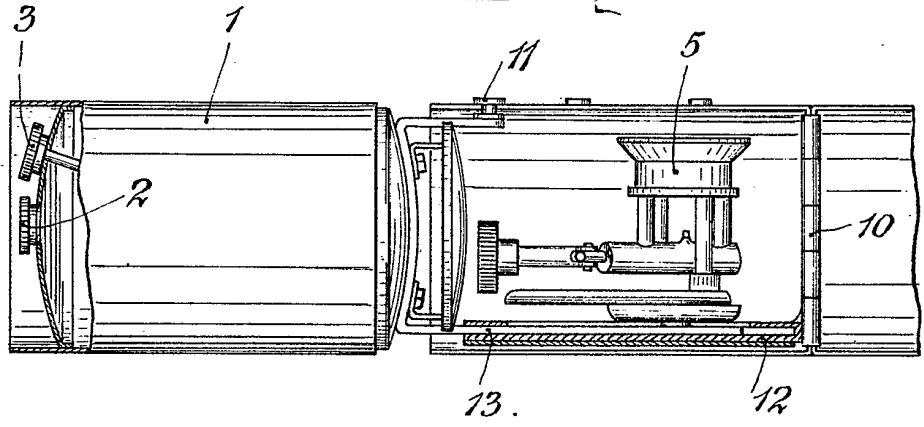
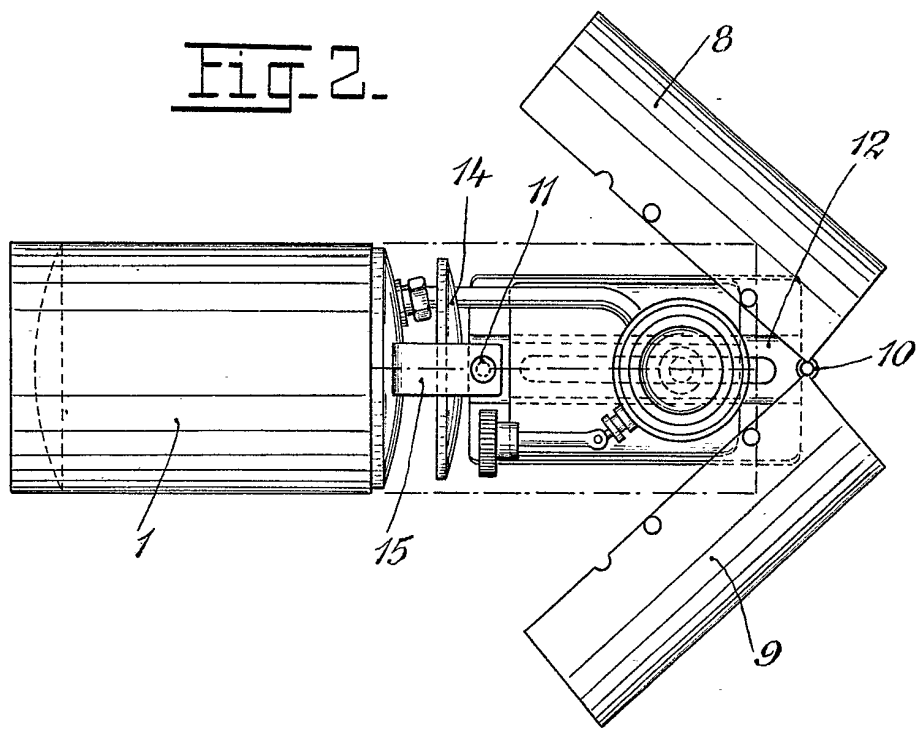

Fig. 2.



[This Drawing is a reproduction of the Original on a reduced scale.]